

## Slotted locknuts

with thread locking

### SPECIFICATION

Nut

Steel **ST**

- Tensile strength class 5.8
- blackened

Set screw

Steel, blackened

### INFORMATION

GN 1804.2 slotted locknuts with thread locking can be secured against twisting by twisting off the threaded shaft via a d4 set screw. The thread flanks of the nut ensure damage-free securing and can be used as often as needed.

The d3 offset plane surface is intended as an axial contact surface.

### ACCESSORY

- C-Spanner DIN 1810 (Code no. see table) (see page 994)

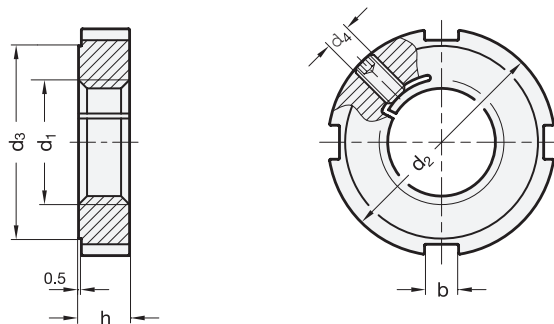

### GN 1804.2

Description	d1	d2	d3	d4	b	h	Code no. for C-Spanner	⚖
GN 1804.2-M12x1,5-ST	M12x1.5	28	23	M4	5	6	DIN 1810-A25-28	20
GN 1804.2-M14x1,5-ST	M14x1.5	30	25	M4	5	7	DIN 1810-A30-32	26
GN 1804.2-M16x1,5-ST	M16x1.5	32	27	M5	5	7	DIN 1810-A30-32	29
GN 1804.2-M18x1,5-ST	M18x1.5	34	28	M5	6	8	DIN 1810-A34-36	35
GN 1804.2-M20x1,5-ST	M20x1.5	36	30	M5	6	8	DIN 1810-A34-36	38
GN 1804.2-M22x1,5-ST	M22x1.5	40	34	M5	6	9	DIN 1810-A40-42	55
GN 1804.2-M24x1,5-ST	M24x1.5	42	36	M5	6	9	DIN 1810-A40-42	58
GN 1804.2-M30x1,5-ST	M30x1.5	50	43	M5	7	10	DIN 1810-A45-50	58
GN 1804.2-M35x1,5-ST	M35x1.5	55	48	M6	7	11	DIN 1810-A52-55	111
GN 1804.2-M40x1,5-ST	M40x1.5	62	54	M8	8	12	DIN 1810-A58-62	150

